



## NTC Thermistors, High Temperature Sensors



### FEATURES

- Small diameter down to 1.7 mm
- Quick response time down to 0.9 s
- Wide temperature range from - 40 to + 200 °C
- Resistant to corrosive atmospheres and harsh environments
- Old part number was 2322 633 3/5/8...
- Component in accordance to RoHS 2002/95/EC and WEEE 2002/96/EC
- Available in bulk or on tape

### APPLICATIONS

High temperature measurement control:  
Domestic appliances  
Automotive systems  
Industrial process control

### DESIGN-IN SUPPORT

For complete Curve Computation, visit:  
<http://www.vishay.com/thermistors/curve-computation-list/>

### DESCRIPTION

These thermistors have a negative temperature coefficient and are mounted in a glass envelope:

2381 633 5... (SOD80) without leads and suitable for surface mounting

2381 633 8... (SOD27) with tinned copper-clad iron leads

2381 633 3... is the bandolier version of 2381 633 8... series

### MOUNTING

By soldering, clamping or welding

QUICK REFERENCE DATA		
PARAMETER	VALUE	
	2381 633 5....	2381 633 8....
Temperature range	- 40 to + 200 °C	
Resistance value at 25 °C ( $R_{25}$ )	10 to 220 k $\Omega$	
Tolerance on $R_{25}$ - value	$\pm 5\%$ and $\pm 10\%$	
$B_{25/85}$ - value	3977K	
Tolerance on $B_{25/85}$ - value	$\pm 1.3\%$	
Deviation in resistance value due to B-tolerance	See Resistance Values at Intermediate Temperatures table for 2381 633 5.... series	See Resistance Values at Intermediate Temperatures table for 2381 633 8.... series
Ratio $R_T/R_{25}$	See Resistance Values at Intermediate Temperatures table for 2381 633 5.... series	See Resistance Values at Intermediate Temperatures table for 2381 633 8.... series
Rated dissipation	100 mW	
Dissipation factor	2.5 mW/K	
Response time	0.9 s	
Thermal time constant $\tau$	6 s	
Temperature coefficient	See Resistance Values at Intermediate Temperatures table for 2381 633 5.... series	See Resistance Values at Intermediate Temperatures table for 2381 633 8.... series
Climatic category	40/155/56	40/200/56
Mass	$\approx 0.03$ g	$\approx 0.14$ g

### ELECTRICAL DATA AND ORDERING INFORMATION

$R_{25}$ (k $\Omega$ )	$B_{25/85}$ - VALUE	12NC ORDERING CODE 2381 633 3/8... <sup>(1)</sup>	SAP MATERIAL NO. NTCLG100E2... <sup>(2)</sup>	12NC ORDERING CODE 2381 633 5... <sup>(1)</sup>	SAP MATERIAL NO. NTCSMELFE3... <sup>(2)</sup>
10	3977 K $\pm 1.3\%$	*103	103*B	*103	103*T
20	3977 K $\pm 1.3\%$	*203	203*B	*203	203*T
30	3977 K $\pm 1.3\%$	*303	303*B	*303	303*T
100	3977 K $\pm 1.3\%$	*104	104*B	*104	104*T
220	3797 K $\pm 3.0\%$	*224	224*B	-	-

#### Notes

<sup>(1)</sup> Replace \* in 12NC by 3 for 5 %, 2 for 10 % tolerance on  $R_{25}$  °C, the 8th digit stands for packing: 8 for bulk and 3 for taped components

<sup>(2)</sup> Replace \* in SAP part no by J for 5 %, K for 10 % tolerance on  $R_{25}$  °C, for NTCLG100E2 parts, replace last character by B for bulk and by T for taped components



**DIMENSIONS** in millimeters

Component outline for 2381 633 8.... (SOD27)

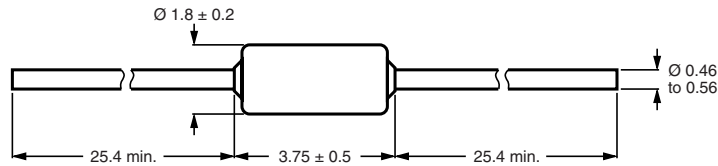

Component outline for 2381 633 5.... (SOD80)

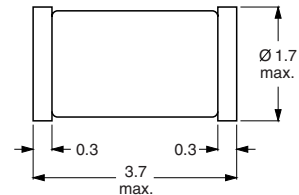

**DERATING**

Derating curve for 2381 633 5.... series

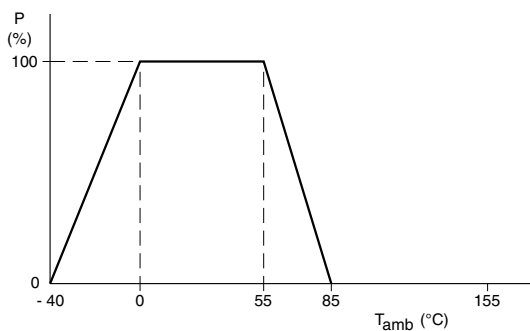

Derating curve for 2381 633 8.... series

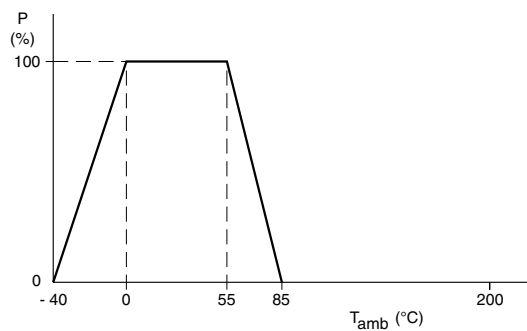

**STABILITY AND R-T CHARACTERISTICS**

Stability of glass encapsulated NTCs after thermal shock test

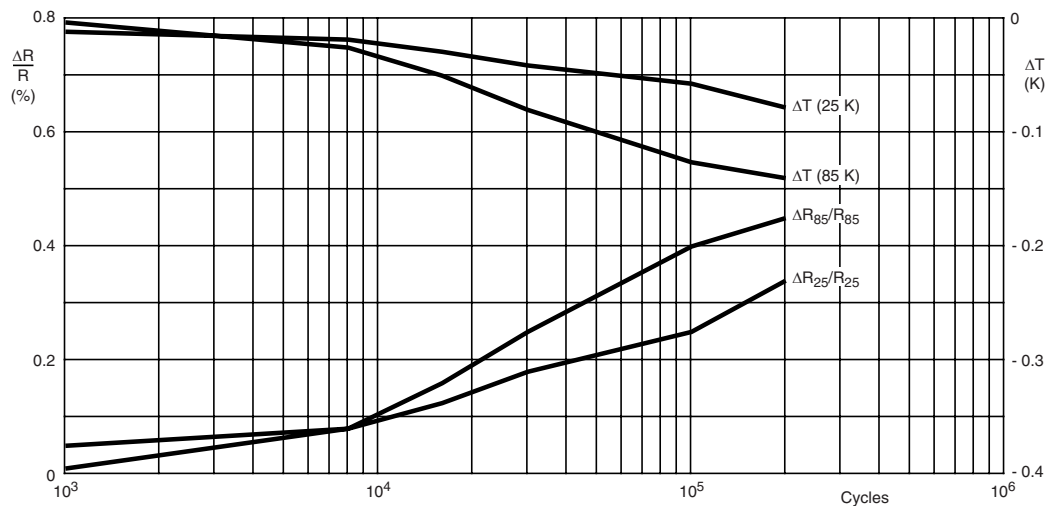



# 2381 633 3/8..../NTCLG100E2..... and 2381 633 5..../NTCSMELFE3....T

NTC Thermistors, High Temperature Sensors Vishay BCcomponents

## STABILITY AND R-T CHARACTERISTICS

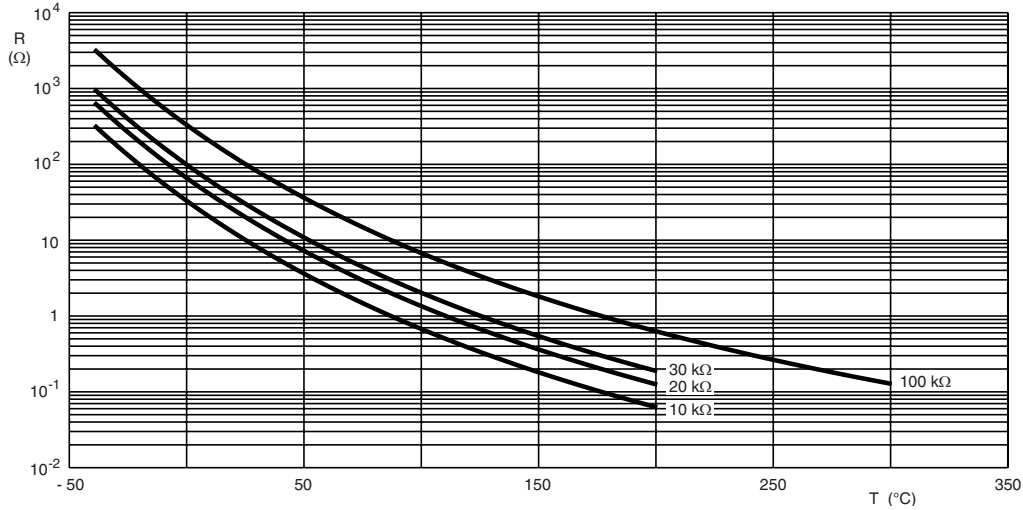

For complete Curve Computation, visit: <http://www.vishay.com/thermistors/curve-computation-list/>

### RESISTANCE VALUES AT INTERMEDIATE TEMPERATURES FOR 2381 633 5..../NTCSMELFE2...

T <sub>OPER</sub> (°C)	R <sub>T</sub> /R <sub>25</sub>	ΔR DUE TO B-TOLERANCE (%)	TCR (%/K)	R <sub>25</sub> (kΩ) for 2381 633/NTCSMELFE2 (see note 1)			
				5.103/103.T	5.203/203.T	5.303/303.T	5.104/104.T
-40	33.06	4.65	6.59	330.6	661.2	991.8	3306
-35	23.90	4.21	6.37	239.0	478.1	717.1	2390
-30	17.47	3.79	6.16	174.7	349.4	524.1	1747
-25	12.90	3.38	5.96	129.0	258.0	387.0	1290
-20	9.621	2.99	5.77	96.21	192.4	288.6	962.1
-15	7.242	2.61	5.59	72.42	144.8	217.3	724.2
-10	5.501	2.24	5.41	55.01	110.0	165.0	550.1
-5	4.214	1.89	5.24	42.14	84.28	126.4	421.4
0	3.255	1.55	5.08	32.55	65.09	97.64	325.5
5	2.534	1.22	4.93	25.34	50.67	76.01	253.4
10	1.987	0.90	4.78	19.87	39.74	59.62	198.7
15	1.570	0.59	4.64	15.70	31.40	47.10	157.0
20	1.249	0.29	4.51	12.49	24.98	37.46	124.9
25	1.000	0.00	4.38	10.00	20.00	30.00	100.0
30	0.8059	0.28	4.25	8.059	16.12	24.18	80.59
35	0.6534	0.55	4.13	6.534	13.07	19.60	65.34
40	0.5329	0.82	4.02	5.329	10.66	15.99	53.29
45	0.4371	1.08	3.91	4.371	8.742	13.11	43.71
50	0.3604	1.34	3.80	3.604	7.209	10.81	36.04
55	0.2988	1.58	3.70	2.988	5.976	8.963	29.88
60	0.2489	1.82	3.60	2.489	4.978	7.467	24.89
65	0.2084	2.06	3.51	2.084	4.168	6.251	20.84
70	0.1753	2.29	3.42	1.753	3.505	5.258	17.53
75	0.1481	2.51	3.33	1.481	2.961	4.442	14.81
80	0.1256	2.73	3.24	1.256	2.512	3.769	12.56
85	0.1070	2.95	3.16	1.070	2.141	3.211	10.70
90	0.09156	3.16	3.08	0.9156	1.831	2.747	9.156
95	0.07862	3.36	3.01	0.7862	1.572	2.359	7.862
100	0.06777	3.56	2.93	0.6777	1.355	2.033	6.777
105	0.05863	3.76	2.86	0.5863	1.173	1.759	5.863
110	0.05089	3.95	2.79	0.5089	1.018	1.527	5.089
115	0.04433	4.13	2.73	0.4433	0.8865	1.330	4.433
120	0.03873	4.32	2.66	0.3873	0.7747	1.162	3.873
125	0.03395	4.50	2.60	0.3395	0.6791	1.019	3.395
130	0.02985	4.67	2.54	0.2985	0.5971	0.8956	2.985
135	0.02633	4.84	2.49	0.2633	0.5265	0.7898	2.633
140	0.02328	5.01	2.43	0.2328	0.4656	0.6984	2.328
145	0.02065	5.17	2.38	0.2065	0.4129	0.6194	2.065
150	0.01836	5.33	2.32	0.1836	0.3671	0.5507	1.836

# 2381 633 3/8.../NTCLG100E2..... and 2381 633 5.../NTCSMELFE3....T



Vishay BCcomponents NTC Thermistors, High Temperature Sensors

For complete Curve Computation, visit: <http://www.vishay.com/thermistors/curve-computation-list/>

RESISTANCE VALUES AT INTERMEDIATE TEMPERATURES FOR 2381 633 8.../NTCLG100E2...							
T <sub>OPER</sub> (°C)	R <sub>T</sub> /R <sub>25</sub>	ΔR DUE TO B-TOLERANCE FOR 103/203/303/104 (%)	TCR (%/K)	R (kΩ) for 2381 633/NTCLG100E2 <sup>(1)</sup>			
				8.103/103.T	8.203/203.T	8.303/303.T	8.104/104.T
-40	33.06	4.65	6.59	330.6	661.2	991.8	3306
-35	23.90	4.21	6.37	239.0	478.1	717.1	2390
-30	17.47	3.79	6.16	174.7	349.4	524.1	1747
-25	12.90	3.38	5.96	129.0	258.0	387.0	1290
-20	9.621	2.99	5.77	96.21	192.4	288.6	962.1
-15	7.242	2.61	5.59	72.42	144.8	217.3	724.2
-10	5.501	2.24	5.41	55.01	110.0	165.0	550.1
-5	4.214	1.89	5.24	42.14	84.28	126.4	421.4
0	3.255	1.55	5.08	32.55	65.09	97.64	325.5
5	2.534	1.22	4.93	25.34	50.67	76.01	253.4
10	1.987	0.90	4.78	19.87	39.74	59.62	198.7
15	1.570	0.59	4.64	15.70	31.40	47.10	157.0
20	1.249	0.29	4.51	12.49	24.98	37.46	124.9
25	1.000	0.00	4.38	10.00	20.00	30.00	100.0
30	0.8059	0.28	4.25	8.059	16.12	24.18	80.59
35	0.6534	0.55	4.13	6.534	13.07	19.60	65.34
40	0.5329	0.82	4.02	5.329	10.66	15.99	53.29
45	0.4371	1.08	3.91	4.371	8.742	13.11	43.71
50	0.3604	1.34	3.80	3.604	7.209	10.81	36.04
55	0.2988	1.58	3.70	2.988	5.976	8.963	29.88
60	0.2489	1.82	3.60	2.489	4.978	7.467	24.89
65	0.2084	2.06	3.51	2.084	4.168	6.251	20.84
70	0.1753	2.29	3.42	1.753	3.505	5.258	17.53
75	0.1481	2.51	3.33	1.481	2.961	4.442	14.81
80	0.1256	2.73	3.24	1.256	2.512	3.769	12.56
85	0.1070	2.95	3.16	1.070	2.141	3.211	10.70
90	0.09156	3.16	3.08	0.9156	1.831	2.747	9.156
95	0.07862	3.36	3.01	0.7862	1.572	2.359	7.862
100	0.06777	3.56	2.93	0.6777	1.355	2.033	6.777
105	0.05863	3.76	2.86	0.5863	1.173	1.759	5.863
110	0.05089	3.95	2.79	0.5089	1.018	1.527	5.089
115	0.04433	4.13	2.73	0.4433	0.8865	1.330	4.433
120	0.03873	4.32	2.66	0.3873	0.7747	1.162	3.873
125	0.03395	4.50	2.60	0.3395	0.6791	1.019	3.395
130	0.02985	4.67	2.54	0.2985	0.5971	0.8956	2.985
135	0.02633	4.84	2.49	0.2633	0.5265	0.7898	2.633
140	0.02328	5.01	2.43	0.2328	0.4656	0.6984	2.328
145	0.02065	5.17	2.38	0.2065	0.4129	0.6194	2.065
150	0.01836	5.33	2.32	0.1836	0.3671	0.5507	1.836
155	0.01636	5.49	2.27	0.1636	0.3273	0.4909	1.636
160	0.01455	5.65	2.23	0.1455	0.2910	0.4365	1.455
165	0.01303	5.80	2.18	0.1303	0.2606	0.3909	1.303
170	0.01169	5.95	2.14	0.1169	0.2339	0.3508	1.169
175	0.01052	6.10	2.09	0.1052	0.2104	0.3156	1.052
180	0.00948	6.24	2.05	0.09484	0.1897	0.2845	0.9484
185	0.00857	6.38	2.01	0.08569	0.1714	0.2571	0.8569
190	0.00776	6.52	1.97	0.07757	0.1551	0.2327	0.7757
195	0.00704	6.66	1.93	0.07037	0.1407	0.2111	0.7037
200	0.00640	6.79	1.89	0.06396	0.1279	0.1919	0.6396

**Note**

<sup>(1)</sup> Replace dot according to the following rule and depending on requested tolerance on R<sub>25</sub> °C:

- a) for 12NC 3 for 5 % and 2 for 10 % tolerance
- b) for SAP ordering code J for 5 % and K for 10 % tolerance



# 2381 633 3/8.../NTCLG100E2..... and 2381 633 5.../NTCSMELFE3....T

NTC Thermistors, High Temperature Sensors Vishay BCcomponents

For complete Curve Computation, visit: <http://www.vishay.com/thermistors/curve-computation-list/>

<b>RESISTANCE VALUES AT INTERMEDIATE TEMPERATURES FOR 2381 633 83224/NTCLG100E2224T</b>				
<b>T<sub>OPER</sub> (°C)</b>	<b>R<sub>T</sub>/R<sub>25</sub></b>	<b>ΔR DUE TO B-TOLERANCE FOR 224 (%)</b>	<b>TCR (%/K)</b>	<b>RESISTANCE (Ω)</b>
-40	25.7830	10.49	-6.07	5 672 263.60
-35	19.1253	9.48	-5.88	4 207 576.09
-30	14.3200	8.51	-5.70	3 150 399.51
-25	10.8187	7.58	-5.52	2 380 123.99
-20	8.2444	6.69	-5.35	1 813 764.23
-15	6.3349	5.83	-5.19	1 393 675.05
-10	4.9066	5.01	-5.03	1 079 441.58
-5	3.8294	4.21	-4.88	842 474.22
0	3.0108	3.44	-4.74	662 372.59
5	2.3839	2.71	-4.60	524 457.34
10	1.9004	1.99	-4.47	418 079.84
15	1.5248	1.31	-4.34	335 454.71
20	1.2311	0.64	-4.22	270 846.73
25	1.0000	0.00	-4.10	220 000.00
30	0.8170	0.62	-3.99	179 733.97
35	0.6712	1.22	-3.88	147 655.51
40	0.5543	1.80	-3.77	121 952.04
45	0.4602	2.37	-3.67	101 241.94
50	0.3839	2.91	-3.58	84 465.62
55	0.3218	3.44	-3.48	70 805.57
60	0.2710	3.95	-3.39	59 627.46
65	0.2293	4.45	-3.30	50 436.33
70	0.1947	4.93	-3.22	42 843.93
75	0.1661	5.40	-3.14	36 544.07
80	0.1422	5.86	-3.06	31 294.12
85	0.1223	6.30	-2.99	26 900.84
90	0.1055	6.74	-2.92	23 209.62
95	0.0913	7.16	-2.85	20 096.19
100	0.0794	7.56	-2.78	17 460.22
105	0.0692	7.96	-2.71	15 220.36
110	0.0605	8.35	-2.65	13 310.39
115	0.0531	8.73	-2.59	11 676.18
120	0.0467	9.09	-2.53	10 273.29
125	0.0412	9.45	-2.47	9065.15
130	0.0365	9.80	-2.42	8021.51
135	0.0324	10.14	-2.37	7117.27
140	0.0288	10.47	-2.31	6331.54
145	0.0257	10.80	-2.26	5646.86
150	0.0229	11.12	-2.22	5048.62
155	0.0206	11.43	-2.17	4524.53
160	0.0185	11.73	-2.12	4064.21
165	0.0166	12.02	-2.08	3658.90
170	0.0150	12.31	-2.04	3301.16
175	0.0136	12.60	-2.00	2984.68
180	0.0123	12.87	-1.95	2704.05
185	0.0112	13.14	-1.92	2454.67
190	0.0101	13.41	-1.88	2232.58
195	0.0092	13.67	-1.84	2034.38
200	0.0084	13.92	-1.81	1857.14

**PACKAGING**

**BLISTER TAPE AND REEL (2381 633 5....)**

Blister tape

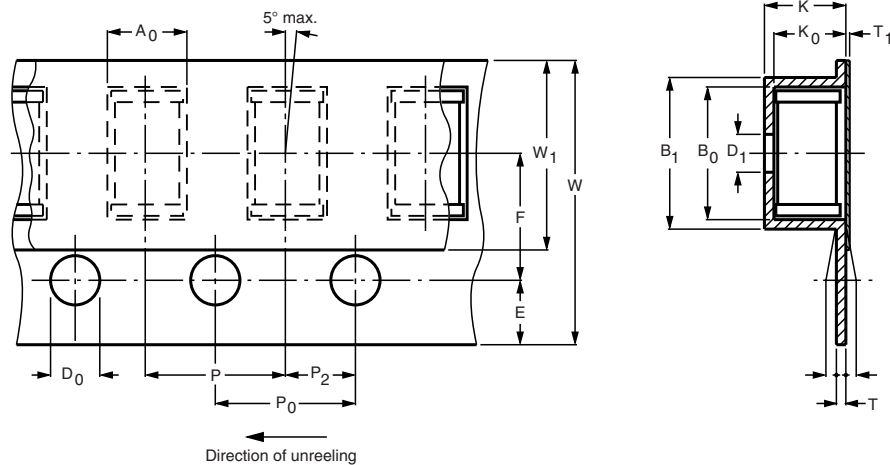

Reel

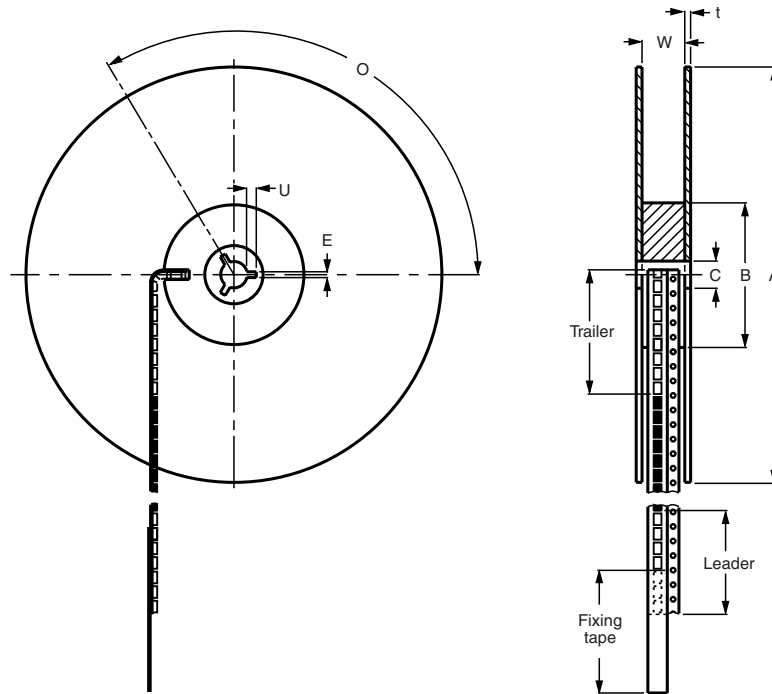

<b>BLISTER TAPE AND REEL DIMENSIONS</b>				
SYMBOL	PARAMETER	NOMINAL DIMENSIONS	TOLERANCE	UNIT
<b>Blister tape</b>				
K	Overall thickness	< 2.5	-	mm
<b>POCKET</b>				
$A_0$	Length	2.1	+ 0.3	mm
$B_0$	Width	> 3.8	-	mm
$K_0$	Depth	2.1	+ 0.3	mm
$B_1$	Outside width	< 4.5	-	mm



# 2381 633 3/8.../NTCLG100E2..... and 2381 633 5.../NTCSMELFE3....T

NTC Thermistors, High Temperature Sensors Vishay BCcomponents

BLISTER TAPE AND REEL DIMENSIONS				
SYMBOL	PARAMETER	NOMINAL DIMENSIONS	TOLERANCE	UNIT
P	Pitch	4.0	± 0.1	mm
D <sub>1</sub>	Hole diameter	1.0	± 0.1	mm
FEED-HOLE				
D <sub>0</sub>	Diameter	1.5	± 0.1	mm
P <sub>0</sub>	Pitch	4.0	± 0.1	mm
E	Distance	1.75	± 0.1	mm
	Cumulative pitch error over 10 positions	0	± 0.1	mm
CENTRE LINE				
P <sub>2</sub>	Length	2.0	± 0.05	mm
F	Width	3.5	± 0.1	mm
FIXING TAPE				
W <sub>1</sub>	Width	< 5.5	-	mm
T <sub>1</sub>	Thickness	< 0.1	-	mm
CARRIER TAPE				
W	Thickness	8.0	± 0.2	mm
δ	Bending	< 0.3	-	mm
T	Thickness	< 0.4	-	mm
<b>Reel</b>				
FLANGE				
A	Diameter	180	+ 0	mm
t	Thickness	1.5	+ 0.5	mm
W	Space between flanges	9.5	± 0.5	mm
HUB				
B	Diameter	62.0	± 1.5	mm
C	Spindle hole	12.75	+ 0.15/- 0	mm
KEY SLIT				
E	Width	2.0	± 0.5	mm
U	Depth	4.0	± 0.5	mm
O	Location	120	-	°

## THERMISTORS ON BANDOLIER (2381 633 3....)

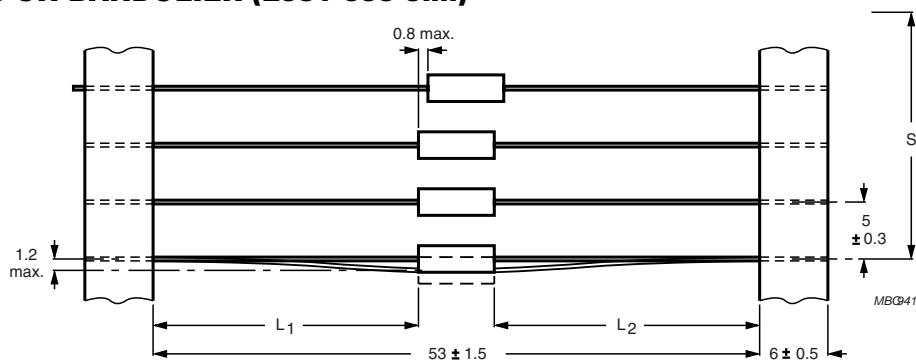

The components are centred so that  $|L_1 - L_2| = 1.2 \text{ mm max.}$   
 The cumulative space (S) measured over 10 spacings =  $50 \pm 2 \text{ mm.}$

### Note

The bandolier of a 180 mm reel contains at least 2500 devices with no more than 0.5 % empty positions. Three consecutive empty places may be found provided this gap is followed by 6 consecutive devices. The carrier tape starts (leader) and ends (trailer) with at least 75 empty positions (equivalent to 300 mm); the covering foil is at least 300 mm. In order to fix the carrier tape a self-adhesive tape of 20 to 50 mm width is applied.



## Disclaimer

All product specifications and data are subject to change without notice.

Vishay Intertechnology, Inc., its affiliates, agents, and employees, and all persons acting on its or their behalf (collectively, "Vishay"), disclaim any and all liability for any errors, inaccuracies or incompleteness contained herein or in any other disclosure relating to any product.

Vishay disclaims any and all liability arising out of the use or application of any product described herein or of any information provided herein to the maximum extent permitted by law. The product specifications do not expand or otherwise modify Vishay's terms and conditions of purchase, including but not limited to the warranty expressed therein, which apply to these products.

No license, express or implied, by estoppel or otherwise, to any intellectual property rights is granted by this document or by any conduct of Vishay.

The products shown herein are not designed for use in medical, life-saving, or life-sustaining applications unless otherwise expressly indicated. Customers using or selling Vishay products not expressly indicated for use in such applications do so entirely at their own risk and agree to fully indemnify Vishay for any damages arising or resulting from such use or sale. Please contact authorized Vishay personnel to obtain written terms and conditions regarding products designed for such applications.

Product names and markings noted herein may be trademarks of their respective owners.